

DR. SAHNI'S CONTRIBUTION TO INDIAN NUMISMATICS

V. S. AGRAWALA

Superintendent, Archaeological Survey of India

“THAT a palaeobotanist, with no pretensions to a knowledge of archaeology, should here venture into the field of numismatics, demands an explanation” — thus Dr. Sahni begins his great memoir on the “Technique of Casting Coins in Ancient India”, which the Numismatic Society of India had the honour to publish in 1945. Being connected with the actual publication of this work and also sharing the honour and the privilege of watching the progress of the memoir when the great scientist was at it, I here record as a reminiscence my impressions of Dr. Sahni formed at that time. Dr. Sahni used to visit the Lucknow Museum frequently in connection with his work during my curatorship, and this became instrumental in bringing us into intimate touch with each other.

The accidental discovery of some thousands of terra-cotta coin moulds (FIG. 1) with a few virgin coins still lying within their wombs, from the Khokra Kot Mound, near Rohtak, was one of the luckiest events ever recorded in the history of Indian numismatics. Dr. Sahni, with his characteristic zeal and training as a scientist, immediately recognized the value of the find and promptly followed it up by announcing the discovery in the May number of *Current Science* (1936) in an article entitled “Antiquities from the Khokra Kot Mound at Rohtak in the Jumna Valley”.

Even this contribution would have been considered substantial enough for one whose main interest lay elsewhere, in the field of palaeobotany; but Dr. Sahni possessed a much wider intellectual equipment combined with rare enthusiasm to tackle new sources of knowledge, specially if they happened to be in the form of concrete material offering scope for

minute observation and interpretation of the evidence writ on its visage. But, perhaps, this particular interest in something really concerned with ancient India may be attributed to his early training in Sanskrit which, as he told me at a later date, was one of the subjects for his Matriculation. He treated the fragmentary pieces of coin moulds with the same patience and understanding as he had been wont to apply to plant fossils. Once he had set apart a compartment of his brain for this material, his mind was constantly working like a sieve, sifting evidence from many a source that he could lay his hands upon. Not only did he consult leading archaeologists in India like the late Dr. K. P. Jayaswal who at once realized the importance of the find and encouraged Dr. Sahni to undertake a study of the coin-casting apparatus in ancient India, but also approached foreign experts for the elucidation of his material. He also contacted



TEXT-FIG. 1—Reconstruction of the obverse face of a disc (after Sahni).

the Department of Archaeology and persuaded the then Director General of Archaeology, the late Rao Bahadur K. N. Dikshit, to inspect the Khokra Kot Mound on March 16, 1937, as a result of which it was decided by the Department to make a trial excavation at the site.

With his broad outlook in the comparative treatment of fossils he earnestly began an enquiry about other coin moulds previously found but not adequately noticed or subjected to proper scientific scrutiny. Soon it was found that coin moulds had already come to light at ten other ancient sites, but the material was lying either unnoticed or very cursorily treated. Dr. Sahni immediately instituted a vigorous enquiry to locate the material in the various museums, to obtain the original specimens for personal examination, to subject them to almost microscopic scrutiny and thus develop a mass of comparative facts and reflect this light on his own material from Khokra Kot, which eventually revealed to him the secrets of the technique of casting coins in ancient India. Inevitably his study developed into a comprehensive dissertation on the entire material of coin moulds available in India. Thus he discharged not only the responsibility of the Khokra Kot find, which a kind Providence had placed in his hands, but perfected a thorough commentary on the kindred materials deposited in remote parts of the country under the custody of museum curators and archaeologists. Dr. Sahni virtually gave tongue to those ordinary fragments of clay known as coin moulds which, although the source of that most coveted object, the coin, are themselves destined to lie in oblivion. As he himself graphically put it: "Unlike the coin made from it, the coin mould or die never passes into circulation. While the coin is peripatetic, the mould is static. The mould, therefore, has a historical value of its own, supplementing that of the coin: apart from throwing light upon the technique employed it reveals the birth-place of the coin, from where it started on its long peregrinations" (SAHNI, 1945, p. 4). He as a scientist was also enabled to probe into the shape of things to come and remarked that it would not at all be rash to predict that with further investigation the matrices of the majority of cast coins would come to light. The prediction has partly been fulfilled and is enough to make the future excavator maintain a cautious look-

out for the coin mould material during the course of his digging.

In the objective study of this material Dr. Sahni employed all those devices which he applied to the study of fossilized relics. The moulds were accurately measured, drawn, reconstructed, and fresh similar clay moulds made and baked in order to ascertain the temperatures that would have been required in the baking of the old moulds. The clay of the moulds as well as some of the coins were subjected to microscopic examination to determine their composition. As a characteristic instance of the maximum pains he had taken, I might mention an instance of a coin mould of Jaya Gupta from Nalanda. At two points round the cylinder there were adhering small patches of clay, of the same grey colour as the mould itself. It was only a thin crust which on casual observation might easily be passed over as adhering dirt, but it was hard, baked clay. Dr. Sahni at once summoned his constant companion, the pocket lens, to help him and it revealed "at four or five spots... the impressions of vegetable matter, probably the husk of some cereal with the epidermal cell outlines clearly marked on the crust. I have no doubt we have here the remains of an originally much thicker and complete layer of plaster made up, like that on the Rohtak and Sunet moulds, of clay mixed with fibrous vegetable matter" (SAHNI, 1945, pp. 37, 38). The small speck of clay thus subjected to enlargement gave evidence of a luting that once enveloped the mould and contained vegetable matter in which cell structure was clearly visible. Following up a suggestion from his great friend Prof. H. J. Bhabha, he X-rayed some of the coupled moulds to ascertain whether they contained any coins. This was introducing romance in the rather dry field of archaeology in trying to visualize the coin as it lay in the womb of its matrix. As science relies on visual documentation for its statements, absolutely distinct and accurate photographs and text-figures were prepared to illustrate each detailed point, and it appears that Dr. Sahni's trained staff exercised the same care in the preparation of the fascinating photographs numbering one hundred and forty-four for his memoir as they were accustomed to do in the case of fossilized relics, millions of years old. Seldom before had archaeological material been photographed to greater advantage in this country.

The figure illustrating a reconstruction of the Rohtak coin mould, as it would look when complete for the operation of casting, bears reproduction (FIG. 2) as it represents in a nutshell the substance of Dr. Sahni's researches on the subject. For the interest of readers, who may not have a chance of looking at the original memoir, I may be permitted to quote his own words for a description :

"... The mould was made up of a series of discs placed in a vertical column, like a pile of coins. The whole pile was plastered over with clay, only a funnel-like crater being left at the top for receiving the molten metal. The crater led vertically down into a central canal, like the shaft of a mine. From this canal, again as in a mine, horizontal channels led out at different levels, and these opened into the coin sockets. At each level eight such channels

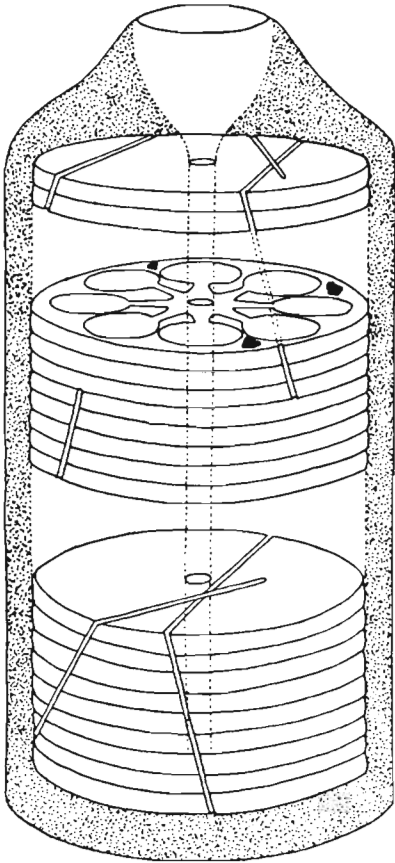

TEXT-FIG. 2—Reconstruction of the Rohtak coin mould (after Sahni).

radiated from the central shaft, and opened into as many coin sockets arranged in a ring... The coupled faces of contiguous discs bore the negative impressions of the obverse and reverse, respectively, and were so placed as to make the opposing sockets coincide exactly...

"After the metal had been poured in and the mould was cool enough it was broken up and the coins, attached in whorls at the ends of the spokes, were broken off, the remaining metal being again put into the melting pot" (SAHNI, 1945, pp. 18, 19). Also, "The clay luting round the entire mould served to bind the discs into a compact pile and prevented the leakage of metal. At the same time the porous nature of the luting allowed the escape of hot gases in advance of the inflowing metal. The importance of mixing husk and grain with the clay of the plaster will now be evident: when the mould was baked, the combustion of the vegetable matter left the plaster in a porous condition and yet strong enough to hold the discs together" (loc. cit., p. 26). The complex technique followed at the Yaudheya mint seems to be quite efficient and must have been backed by a long series of experiments.

Apart from the complete revelation of the technique of casting coins forthcoming as a result of Dr. Sahni's study of the Khokra Kot material, it is necessary to mention the historical significance of his discovery, since this aspect of the problem also was discussed threadbare by him. Within five weeks of his coming to possess the material, Dr. Sahni contacted Dr. K. P. Jayaswal, the distinguished indologist and pioneer authority on republics in ancient India, who deciphered completely the legend on the plasticine positives prepared by Dr. Sahni from a large number of well-preserved fragments of the negatives as *Yaudheyānā(m) Bahudhāñake*, i.e. (coins) of the *Yaudheyās of Bahudhāñaka*. Although the coins of the Yaudheyas had been known for more than a century, we were for the first time face to face with one of their mint-towns, precisely located in the suburbs of Rohtak, and what was more valuable still, the name of an important section of the Yaudheya republic of Bahudhānyaka was in evidence. The find provided archaeological confirmation of the description of the Yaudheyas of Bahudhānyaka embodied in the *Mahābhārata* (*Sabhāparvan*, Ch.

32, 4, 5), which put the seal of authenticity on the historical and geographical background of the great epic. It was hailed as a thrilling discovery by archaeologists and historians all over India. The late Prof. K. P. Jayaswal announced Dr. Sahni's significant discovery in his presidential address to the Numismatic Society of India meeting at Udaipur in November 1936.

Dr. Sahni himself, once initiated by Prof. Jayaswal into the mystery of the Brāhmī script, exhibited his usual scientific thoroughness in mastering the various forms of each letter and recording like a trained epigraphist the many variations in the designs and script noticed on the several thousands of fragments (SAHNI, 1945, TEXT-FIG. 4, pp. 16, 17). All the unsuccessful attempts in the intriguing quest to read the legend by Cunningham, Vincent Smith and last of all by Allan, who offered the reading *Kupradhanaba* for *Bahudhānyaka* (ALLAN, 1936, pp. 267-270; SAHNI, 1945, pp. 12, 13) were examined by him. The readings of Prof. Jayaswal and Dr. Sahni were a triumph for Prof. Rapson's conjectured readings of over forty years ago, "*Bahudhānyake*". The entire geographical, historical and numismatic data about Bahudhānyaka was, however, revealed for the first time by the present discovery and the evidence was now posed with a clarity which entitled it to a recognized place in the text-books of Indian history.

For studying the technical side, how the moulds were made and how the coins were actually cast, Dr. Sahni took advantage of the relevant literature available in Europe embodying detailed studies of Roman coins. "For consulting the reference literature on early coining techniques, which is surprisingly scarce in India, an enforced visit to Vienna in the summer of 1938 served me in good stead. It brought me into contact with that able and kind-hearted gentleman, Professor K. Pink, who was then in charge of the famous Muenzkabinett at the Kunsthistorisches Museum. Professor Pink... generously placed at my disposal the full facilities of his library and his own fund of knowledge of Roman coins..." (SAHNI, 1945, p. 3). The Rohtak coin mould material is datable to about 1st century B.C., whereas the material from the Roman sites in Europe and Africa belongs to the early centuries of the Christian era. It is indeed

most remarkable that the technique of casting coins, evolved in India about a couple of centuries preceding the Christian era, was so complex, efficient and perfect in every detail. The details of the later Roman technique which was to encase the series of moulds in a luting of plaster, with a wide opening at one end leading into the interior, and the entire mould, with the luting, being hardened by baking before the metal was poured in, is substantially the same as the technique of the earlier multiple mould of the Yaudheyas of Bahudhānyaka. The description of the technical process of casting as revealed by the Roman coin moulds, which Dr. Sahni has summarized in a special chapter of his memoir (pp. 50-54) incorporating the extensive material from the British Isles and Europe, is at once learned and a refreshing treat. He also instituted comparison with the Chinese coin mould material in so far as it was relevant to his study.

The material discussed by Dr. Sahni came from eleven localities, arranged in the following chronological order:

1. Bronze die from Eran, Saugor district, C.P. (c. 3rd century B.C.).
2. Rohtak moulds (c. 100 B.C.).
3. Taxila moulds (c. 15 B.C.).
4. Mathura moulds (probably not older than 2nd or 1st century A.D.).
5. Atranji Khera mould, Etah district, U.P. (Kushāṇa period: 2nd century A.D.).
6. Sanchi moulds of the Western Kshatrapa Dynasty (within the limits c. A.D. 150 and 388).
7. Kondapur (Hyderabad State) moulds for punch-marked, Āndhra and Kshatrapa coins.
8. Sunet moulds, Ludhiana district of the Punjab (c. 3rd century A.D., post-Kushāṇa and pre-Gupta).
9. Kashi mould of the reign of Chandra Gupta II (A.D. 375-417).
10. Nalanda moulds (Gupta period: Narsimhagupta, c. A.D. 500-550; Jaya Gupta, c. A.D. 625-675).
11. Kadkal (Hyderabad State) moulds, (11th-14th century A.D.).

It will thus be seen that Dr. Sahni covered an extensive range in time, almost a period of 1500 years from c. 3rd century B.C. to about 12th century A.D., and also an area extending from Taxila to Hyderabad,

Deccan. His study helps us to understand the technique employed in the casting of those innumerable Indian coins which, in their variety, beauty and importance for national history, hold a unique place in the annals of humanity, as nowhere else in the world is coin material invested with such capital importance for the reconstruction of history as in India. To Dr. Sahni our debt of gratitude is genuine for devoting himself to focus attention on this fascinating subject.

I should like to end this tribute to the great scientist with a personal note. About ten days before the appointed date of the foundation-stone laying ceremony of the Palaeobotanical Institute I received from him an invitation with a personal and affectionate note to be present on the occasion. In reply I conveyed my gratefulness to him, regretting inability to be present on the occasion in person due to preoccupations. Then the thought came

to me to suggest in the same letter that he might take that opportunity of presenting his valuable coin mould material to the Hon'ble Shri Jawaharlal Nehru for the National Museum of India, in which the Prime Minister takes personal interest and which would be a fitting home for the permanent custody of those valuable archaeological relics. Knowing him as I do, I picture to myself his mental approval to that proposal, but its physical execution remained unfulfilled by his sudden and tragic death. It is now a great solace to me, and I believe it will be the same to the departed soul, that the pious Mrs. Sahni has given her approval to the proposal and decided to present to the National Museum of India the Khokra Kot coin mould material discovered by her distinguished husband.*

* The material has been presented by Mrs. Sahni to Pandit Jawaharlal Nehru for the National Museum.

REFERENCES

ALLAN, J. (1936). Catalogue of the Coins of Ancient India in the British Museum. *Brit. Mus. Cat. London*.

SAHNI, B. (1936). Antiquities from the Khokra

Kot Mound at Rohtak in the Jumna Valley. *Cur. Sci.* 4(11): 796-801.

Idem (1945). The Technique of Casting Coins in Ancient India. *Mem. Numis. Soc. Ind.* (1): 1-68.

BIBLIOGRAPHY OF PROFESSOR SAHNI'S PUBLICATIONS

1915. Foreign pollen in the ovules of *Ginkgo* and of fossil plants. *New Phytol.* **14** (4 & 5): 149-151.
- 1915a. The anatomy of *Nephrolepis volubilis* J. Sim. with remarks on the biology and morphology of the genus. *Ibid.* **14** (8 & 9): 251-274.
1916. The vascular anatomy of the tubers of *Nephrolepis*. *Ibid.* **15** (3 & 4): 72-80.
1917. Observations on the evolution of branching in the Filicales. *Ibid.* **16** (1 & 2): 1-23.
1918. On the branching of the Zygopteridean leaf and its relation to the probable 'pinna' nature of *Gyopteris sinuosa*, Goepfert. *Ann. Bot.* **32** (127): 369-379.
1919. (With J. C. Willis). Lowson's text-book of botany (Indian edition). *Univ. Tut. Press, London.*
- 1919a. On an Australian specimen of *Clepsydropsis*. *Ann. Bot.* **33** (129): 81-92.
1920. Petrified plant remains from the Queensland Mesozoic and Tertiary formations. *Queensland Geol. Surv. Publication*. No. 267: 1-48.
- 1920a. On the structure and affinities of *Acmopyle Pancheri*, Pilger. *Phil. Trans. Roy. Soc. London.* **210** (B): 253-310.
- 1920b. (With A. C. Seward). Indian Gondwana plants: a revision. *Mem. Geol. Surv. Ind. Pal. Ind.* **7** (1): 1-41.
- 1920c. On certain archaic features in the seed of *Taxus baccata*, with remarks on the antiquity of the Taxineae. *Ann. Bot.* **34** (133): 117-133.
1921. On a new abnormality in the sporophyll of *Tmesipteris*. *Proc. (8th Ind. Sci. Cong., Calcutta) Asiat. Soc. Bengal* (N.S.). **17** (4): 179.
- 1921a. A stem impression from the plant-bearing beds near Khunmu (Kashmir), provisionally referred to *Gangamopteris Kashmirensis* Seward. *Ibid.*: 200.
- 1921b. Note on the presence of a "tent-pole" in the seed of *Cephalotaxus pedunculata*. *Ann. Bot.* **35** (138): 297-298.
- 1921c. The present position of Indian palaeobotany. *Pres. Add. 8th Ind. Sci. Cong. Cal. Proc. Asiat. Soc. Bengal* (N.S.). **17** (4): 152-175.
1923. On the theoretical significance of certain so-called "abnormalities" in the sporangiophores of the Psilotaceae. *Jour. Ind. Bot. Soc.* **3** (7): 185-191.
- 1923a. On the structure of the cuticle in *Glossopteris angustifolia* Brongn. *Rec. Geol. Surv. Ind.* **54** (3): 277-280.
- 1923b. Modern Psilotaceae and archaic terrestrial plants. *Nature.* **111**: 84.
1924. On the anatomy of some petrified plants from the Government Museum, Madras. *Proc. 11th Ind. Sci. Cong. Bangalore*: 141.
1925. The ontogeny of vascular plants and the theory of recapitulation. *Jour. Ind. Bot. Soc.* **4** (6): 202-216.
- 1925a. (With E. J. Bradshaw). A fossil tree in the Panchet Series of the Lower Gondwanas near Asansol. *Rec. Geol. Surv. Ind.* **58** (1): 77-79.
- 1925b. On *Tmesipteris Vieillardii* Dangeard, an erect terrestrial species from New Caledonia. *Phil. Trans. Roy. Soc. Lond.* **213** (B): 143-170.
1926. The southern fossil floras — A study in plant geography of the past. *Pres. Add. Proc. 13th Ind. Sci. Cong. Bombay*: 229-254.
- 1926a. (With T. C. N. Singh). On some specimens of *Dadoxylon Arberi* Seward from New South Wales & Queensland. *Jour. Ind. Bot. Soc.* **5** (3): 103-112.
1927. On some petrified cones of Indian fossil conifers from the British Museum, London. *Proc. 14th Ind. Sci. Cong. Lahore*: 215.
- 1927a. (With A. K. Mitra). Notes on the anatomy of some New Zealand species of *Dacrydium*. *Ann. Bot.* **41** (161): 75-89.
- 1927b. A note on the floating island and vegetation of Khajjar, near Chamba in the N.W. Himalayas. *Jour. Ind. Bot. Soc.* **6** (1): 1-7.

1928. Some petrified palms from the Central Museum, Nagpur. *Proc. 15th Ind. Sci. Cong. Calcutta* : 228.
- 1928a. On a collection of petrified tree-trunks discovered in Eden Gardens, Calcutta. *Ibid.*
- 1928b. Dicotyledonous plant remains from the Tertiary beds of Assam. *Ibid.* : 294.
- 1928c. Revisions of Indian fossil plants. Pt. I. Coniferales. (a. Impressions and incrustations). *Mem. Geol. Surv. Ind. Pal. Ind.* (N.S.). **11** : 1-49.
- 1928d. On *Clepsydropsis australis*, a Zygopterid tree-fern, with a *Tempskya*-like false stem, from the Carboniferous rocks of Australia. *Phil. Trans. Roy. Soc. London.* **217** (B): 1-37.
1930. The relation of the late Palaeozoic floras to the early Mesozoic floras. *Proc. 5th Int. Bot. Cong. Cambridge* : 503-504.
- 1930a. On *Asterochlaenopsis*, a new genus of Zygopterid tree-ferns from western Siberia. *Phil. Trans. Roy. Soc. London.* **218** (B): 447-471.
1931. On certain fossil epiphytic ferns found on the stems of the Palaeozoic tree-fern *Psaronius*. *Proc. 18th Ind. Sci. Cong. Nagpur* : 270.
- 1931a. (With T. C. N. Singh). Notes on the vegetative anatomy and female cones of *Fitzroya patagonica* (Hook. fil.). *Jour. Ind. Bot. Soc.* **10** (1): 1-20.
- 1931b. Materials for a monograph of the Indian petrified palms. *Proc. Acad. Sci. U.P.* **1** : 140-144.
- 1931c. Revisions of Indian fossil plants. Pt. II. Coniferales. (b. Petrifications). *Mem. Geol. Surv. Ind. Pal. Ind.* (N.S.). **11** : 51-124.
- 1931d. Miscellaneous notes. Supplementary note on revisions of Indian fossil plants. Pt. II. Coniferales (b. Petrifications). *Rec. Geol. Surv. Ind.* **65** (3): 441-442.
1932. Anatomical proof of the cycadophyte affinities of *Taeniopteris spatulata* McCl. *Proc. 19th Ind. Sci. Cong. Bangalore* : 322.
- 1932a. *Palmoxylon Mathuri*, a new species of petrified palms from Cutch, western India. *Ibid.*
- 1932b. *Conites Hobsoni*, a new species of fossil ovuliferous cones from the Rajmahal Series, Bihar. *Ibid.* : 322-323.
- 1932c. On the genera *Clepsydropsis* and *Cladoxylon* of Unger, and on a new genus *Austroclepsis*. *New Phytol.* **31** (4): 270-278.
- 1932d. On the structure of *Zygopteris primaria* (Cotta) and on the relations between the genera *Zygopteris*, *Etapteris*, and *Botrychioxylon*. *Phil. Trans. Roy. Soc. London.* **222** (B): 29-45.
- 1932e. *Homoxylon rajmahalense* gen. et sp. nov., a fossil angiospermous wood, devoid of vessels, from the Rajmahal Hills, Bihar. *Mem. Geol. Surv. Ind. Pal. Ind.* **20** (2): 1-19.
- 1932f. A petrified *Williamsonia* (*W. Sewardiana*, sp. nov.) from the Rajmahal Hills, India. *Ibid.* **20** (3): 1-19.
- 1932g. On a Palaeozoic tree fern, *Grammatopteris Ba'daufi* (Beck) Hirmer, a link between the Zygopteridaceae and Osmundaceae. *Ann. Bot.* **46** (184): 863-877.
- 1932h. Staminal movements in *Gerbera lanuginosa*. *Jour. Ind. Bot. Soc.* **11** (3): 241-242.
1933. The wood anatomy of a homoxylous dicotyledon, *Tetracentron sinense*. *Proc. 20th Ind. Sci. Cong. Patna* : 317.
- 1933a. (With A. R. Rao). On some Jurassic plants from the Rajmahal Hills. *Jour. and Proc. Asiat. Soc. Bengal* (N.S.). **27** (2): 183-208.
- 1933b. *Dadoxylon Zalesskyi*, a new species of Cordaitacean trees from the Lower Gondwanas of India. *Rec. Geol. Surv. Ind.* **66** (4): 414-429.
- 1933c. A fossil pentalocular fruit from Pondicherry, South India. *Ibid.* : 430-437.
- 1933d. On some abnormal leaves of *Ginkgo*. *Jour. Ind. Bot. Soc.* **12** (1): 50-55.
- 1933e. Explosive fruits in *Viscum japonicum* Thunb. *Ibid.* **12** (2): 96-101.
1934. The silicified flora of the Deccan Intertrappean series. Pt. I. General. *Proc. 21st Ind. Sci. Cong. Bombay* : 316-317.
- 1934a. The silicified flora of the Deccan Intertrappean series. Pt. II. Gymnospermous and angiospermous fruits. *Ibid.* : 317-318.
- 1934b. (With B. P. Srivastava). The silicified flora of the Deccan Intertrappean series. Pt. III. *Sausarospermum Fermori*, gen. et sp. nov. *Ibid.* : 318.

- 1934c. Dr. S. K. Mukerji, F.L.S. (1896-1934) (Obituary). *Jour. Ind. Bot. Soc.* **13** (3): 245-249.
- 1934d. (With A. R. Rao). *Rajmahalia paradoxa* gen. et sp. nov. and other Jurassic plants from the Rajmahal Hills. *Proc. Ind. Acad. Sci.* **1** (6): 258-269.
- 1934e. Dr. Dukinfield Henry Scott (Obituary). *Cur. Sci.* **2** (10): 392-395.
- 1934f. The Deccan Traps: Are they Cretaceous or Tertiary? *Ibid.* **3** (4): 134-136.
1935. The relations of the Indian Gondwana flora with those of Siberia and China. *2nd Cong. Stratig. Carb. Heerlen.* **1**: 517-518.
- 1935a. *Homoxylon* and related woods and the origin of angiosperms. *Proc. 6th Int. Bot. Cong. Amsterdam.* **2**: 237-238.
- 1935b. The *Glossopteris* flora in India. *Ibid.*: 245-247.
- 1935c. Recent discoveries in the Rajmahal flora. *Ibid.*: 248-249.
- 1935d. (With A. R. Rao). Further observations on *Rajmahalia paradoxa*. *Proc. Ind. Acad. Sci.* **1** (11): 710-713.
- 1935e. The roots of *Psaronius*, intra-cortical or extra-cortical? A discussion. *Cur. Sci.* **3** (2): 555-559.
- 1935f. Permo-Carboniferous life provinces with special reference to India. *Ibid.* **4** (6): 385-390.
1936. Pollen grains in the stylar canal and in the ovary of an angiosperm. *Ibid.* **4** (8): 587-588.
- 1936a. Antiquities from the Khokra Kot mound at Rohtak in the Jumna Valley. *Ibid.* **4** (11): 796-801.
- 1936b. The Karewas of Kashmir. *Ibid.* **5** (1): 10-16.
- 1936c. The Himalayan uplift since the advent of Man: its culthistorical significance. *Ibid.* **5** (1): 57-61.
- 1936d. A clay seal and a sealing of the Sunga period from the Khokra Kot mound (Rohtak). *Ibid.* **5** (2): 80-81.
- 1936e. The supposed Sanskrit seal from Rohtak: A correction. *Ibid.* **5** (4): 206 & 215.
- 1936f. Wegener's theory of continental drift in the light of palaeobotanical evidence. *Jour. Ind. Bot. Soc.* **15** (5): 319-332.
- 1936g. The Gondwana affinities of the Angara flora in the light of geological evidence. *Nature.* **138**: 720-721.
- 1936h. The occurrence of *Matonidium* and *Weichselia* in India. *Rec. Geol. Surv. Ind.* **71** (2): 152-165.
1937. Speculations on the climates of the Lower Gondwanas of India. *Proc. 17th Int. Geol. Cong. Moscow*: 217-219.
- 1937a. A mesozoic coniferous wood (*Mesembrioxylon shanense* sp. nov.) from the southern Shan states of Burma. *Rec. Geol. Surv. Ind.* **71** (4): 380-388.
- 1937b. (With W. Gothan). Fossil plants from the Po Series of Spiti (N.W. Himalayas). *Ibid.* **72** (2): 195-206.
- 1937c. Remarks on the papers on the *Gigantopteris* flora by Halle and Jongmans. *2nd Cong. Stratig. Carb. Heerlen.* **1935**: 517-518.
- 1937d. An appreciation of the late Sir J. C. Bose. *Sci. & Cult.* **3** (6): 346-347.
- 1937e. Prof. K. K. Mathur (Obituary). *Cur. Sci.* **5** (7): 365-366.
- 1937f. Revolutions in the plant world. *Pres. Add. Proc. Nat. Acad. Sci. Ind.* **7**: 46-60.
- 1937g. The age of the Deccan Trap (General Discussion). *Proc. 24th Ind. Sci. Cong. Hyderabad*: 459-471.
- 1937h. Wegener's theory of continental drift with reference to India and adjacent countries. (General Discussion). *Ibid.*: 502-520.
- 1937i. (With K. P. Rode). Fossil plants from the Intertrappean beds at Mohgaon Kalan in the Deccan,—with a sketch of the geology of the Chhindwara district. *Proc. Nat. Acad. Sci. Ind.* **7** (3): 165-174.
1938. Recent advances in Indian Palaeobotany. *Pres. Add. Botany Section. Proc. 25th Ind. Sci. Cong. Jubil. Sess. Calcutta* (2): 133-176 and *Luck. Univ. Stud.* (2): 1-100.
1939. Discrepancies between the chronological testimony of fossil plants and animals. *Proc. 25th Ind. Sci. Cong. Calcutta.* (4) — Discussion: 156-163 and 195-196.
- 1939a. The relation of the *Glossopteris* flora with the Gondwana glaciation. *Pres. Add. Biol. Sec. Ind. Acad. Sci. Proc. Ind. Acad. Sci.* **9** (1)B: 1-6.
- 1939b. The eastward opening of the Himalayan geosyncline into the Pacific ocean. *Proc. 6th Pacific Sci. Cong.*: 241-244.

1940. The Deccan Traps: an episode of the Tertiary era. Gen. Pres. Add. *Proc. 27th Ind. Sci. Cong. Madras* (2): 1-21. *Prakrati*. 3 (1): 15-35. 1944 (Gujrati trans.). *Prabuddha Karnataka*. 22 (2): 5-19 (Kanarese trans. by H. S. Rao).
- 1940a. The palaeobotanical correlation of coal seams in India. *Proc. Nat. Inst. Sci. Ind.* 6 (3): 581-582.
1941. Yaudheya coin moulds from Sunet near Ludhiana in the Sutlej valley. *Cur. Sci.* 10 (2): 65-67.
- 1941a. Permanent labels for microscope slides. *Ibid.* 10 (11): 485-486.
- 1941b. Indian silicified plants. 1. *Azolla intertrappea* Sahni & H. S. Rao. *Proc. Ind. Acad. Sci.* 14 (6)B: 489-499.
1942. "A short history of the plant sciences" and "The cytoplasm of the plant cell." Reviews. *Cur. Sci.* 11 (9): 369-372.
1943. *Rodeites* gen. nov. *Palaeobotany in India* — IV. *Jour. Ind. Bot. Soc.* 22 (2-4): 179-181.
- 1943a. A new species of petrified palm stems, *Palmoxylon sclerodermum* sp. nov. from the Deccan Intertrappean Series. *Ibid.*: 209-224.
- 1943b. Indian silicified plants. 2. *Enigmo-carpon Parijai* a silicified fruit from the Deccan, with a review of the fossil history of the Lythraceae. *Proc. Ind. Acad. Sci.* 17 (3) B: 59-96.
- 1943c. (With H. S. Rao). A silicified flora from the Intertrappean cherts round Sausar in the Deccan. *Proc. Nat. Acad. Sci. Ind.* 13 (1): 36-75.
- 1943d. (With S. R. N. Rao). On *Chara sausari* sp. nov., a *Chara* (sensu stricto) from the Intertrappean cherts at Sausar in the Deccan. *Ibid.* 13 (3): 215-223.
1944. (With K. R. Surange). A silicified member of the Cyclanthaceae from the Tertiary of the Deccan. *Nature*. 154: 114-115.
- 1944a. (With B. S. Trivedi). The age of the Saline Series in the Punjab Salt Range. *Ibid.* 153: 54.
- 1944b. Age of the Saline Series in the Salt Range, Punjab. *Ibid.* 153: 462.
- 1944c. The age of the Punjab Salt in the light of recent evidence. Pres. Add. *Proc. Nat. Acad. Sci. Ind.* 14 (1-2): 49-66.
- 1944d. Silicified fruits and seeds from Takli, near Nagpur, C.P. (Hislop and Hunter collection). *Palaeobotany in India* — V. *Ibid.*: 80-82.
1945. The technique of casting coins in ancient India. *Mem. Numis. Soc. Ind.* (1): 1-68.
- 1945a. (With B. S. Trivedi). Age of the Saline Series in the Salt Range of the Punjab. *Nature*. 155: 76.
- 1945b. Microfossils and problem of the Salt Range geology. Pres. Add. *Proc. Nat. Acad. Sci. Ind.* 14 (6): i-xxxii.
- 1945c. (With R. V. Sitholey). Some Mesozoic ferns from the Salt Range, Punjab. *Ibid.* 15 (3): 61-73.
- 1945d. Obituary Note on B. P. Srivastava. *Ibid.* 15 (6): 185-187.
1946. The quest for the early traces of the *Glossopteris* flora. (Introduction to C. Virkki's paper, "Spores from the Lower Gondwanas of India and Australia.") *Ibid.* 15 (4-5): i-iv.
- 1946a. A museum of evolution. *Cur. Sci.* 15 (4): 99-100.
- 1946b. Permanent labels for museum specimens in damp tropical climates. *Jour. Ind. Mus.* 1: 107-108.
1947. Microfossils and the Salt Range thrust. Opening address at the 2nd symposium on the age of the Saline Series. *Proc. Nat. Acad. Sci. Ind.* 16 (2-4): i-1.
- 1947a. A silicified cocos-like palm stem, *Palmoxylon (Cocos) sundaram* from the Deccan Intertrappean beds. *Jour. Ind. Bot. Soc. Iyengar Commem. Vol.*: 361-374.
- 1947b. Palaeontology and the measurement of geological time. *Cur. Sci.* 16 (7): 203-206.
- 1947c. Professor George Matthai (Obituary). *Cur. Sci.* 16: 279-280.
- 1947d. Micropalaeontology in geology. Review of "Principles of Micropalaeontology" by M. F. Glaessner. *Nature*. 160: 771.
- 1947e. Some aspects of earth history as revealed by fossils. *Kashi Vidyapith Silver Jubilee Commem. Vol.*: 1-27.
1948. The prospects of palynology in India. *Svensk. Bot. Tidskrift.* 42 (4): 474-477.
- 1948a. The Pentoxyleae: a new group of Jurassic gymnosperms from the Rajmahal Hills of India. *Bot. Gaz.* 110 (1): 47-80.